



---

## Certifications

[IP 68M to 1000m testing](#)

## Mounting Instructions

Clamp encoder to shaft and use torque arm to prevent rotation. Hook up the encoder with the connection as described. Make sure power supply meets specifications

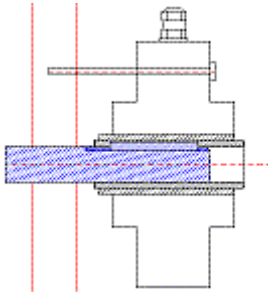

## Dimensions of the 90 mm diameter version (Large)

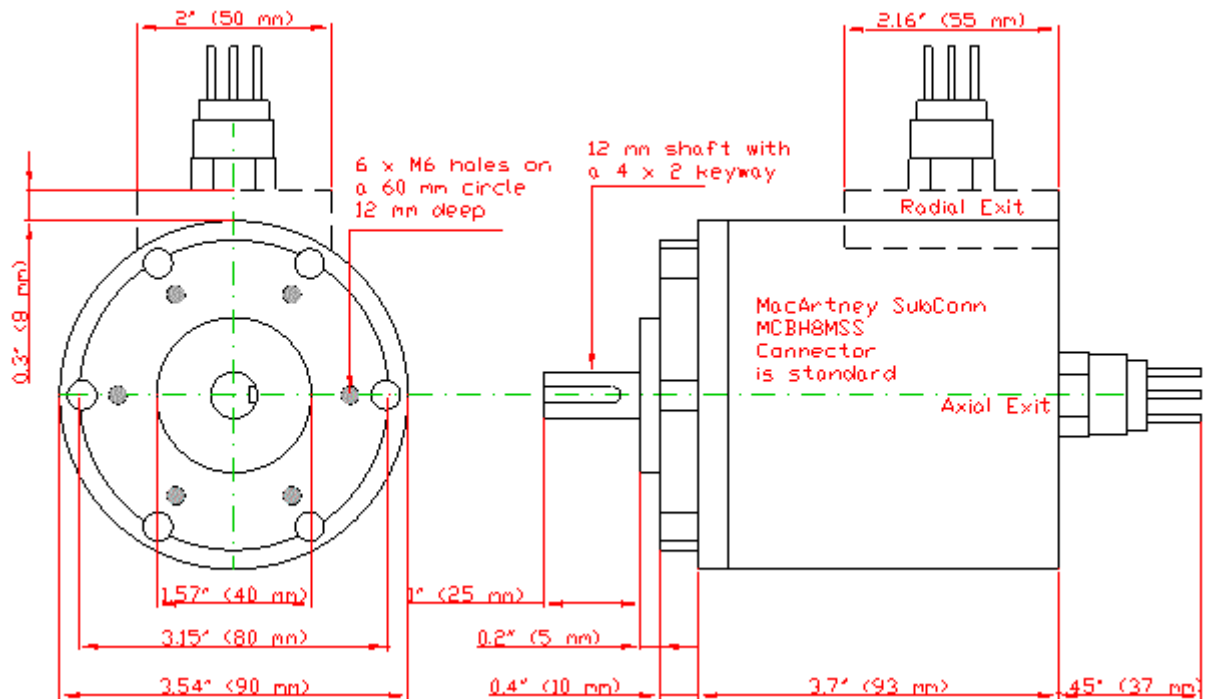

## Dimensions of the 72 mm diameter version (Small)

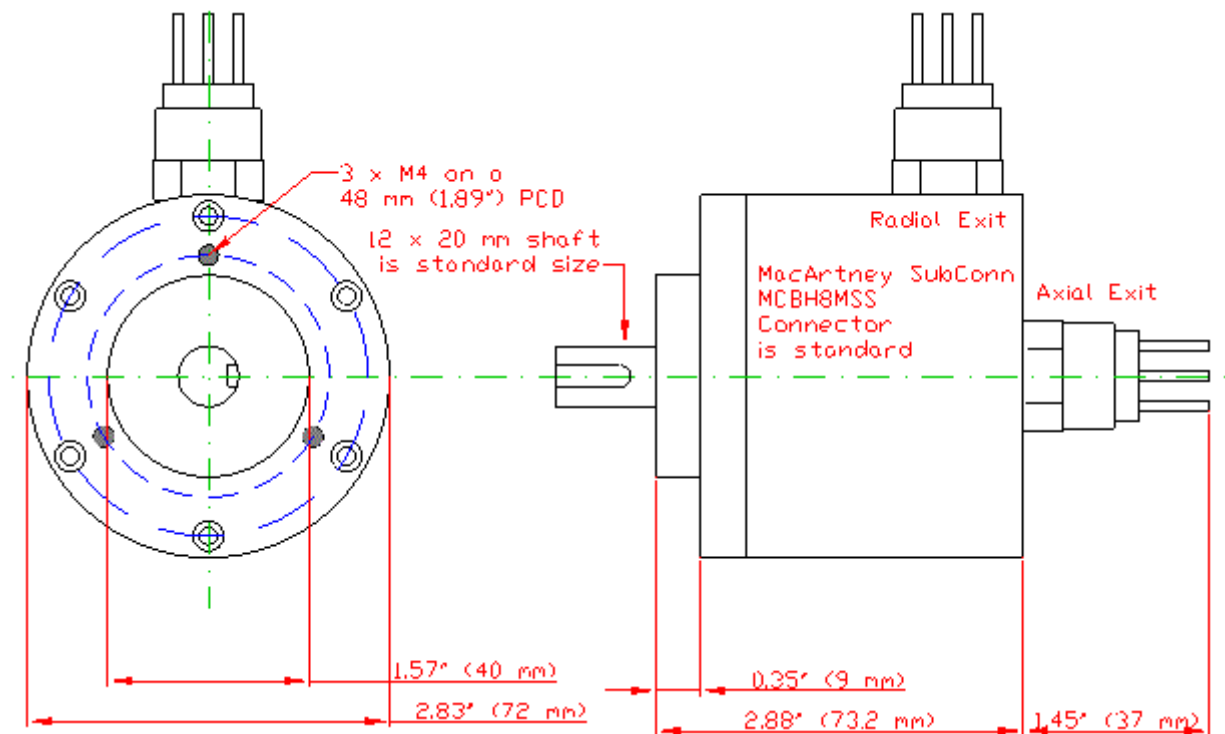

**Hohner Elektrotechnik GmbH**  
Gewerbehof 1  
D-59368 Werne  
Telefon: (0 23 89) 98 78-0  
Telefax: (0 23 89) 98 78-27  
E-Mail: [info@hohner-elektrotechnik.de](mailto:info@hohner-elektrotechnik.de)  
Internet: <http://www.hohner-elektrotechnik.de>